

# Feed Mixers

Truck/Trailer/Stationary

**ROTO-MIX**  
*FORAGE EXPRESS*





The rotor lifts the feed past the wedging point of the lower side auger. This gives you a fluffier ration at lower power requirements. Total feed movement in the mixing chamber eliminates dead spots, pile-up in corners, and auger tunneling through feed, which are common in conventional auger mixers.

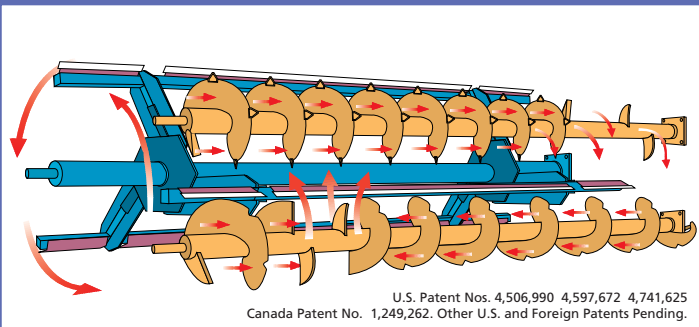
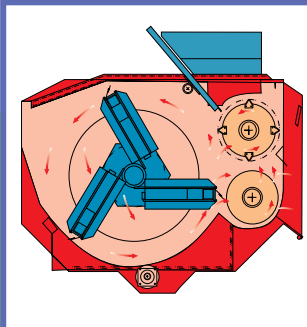

U.S. Patent Nos. 4,506,990 4,597,672 4,741,625  
Canada Patent No. 1,249,262. Other U.S. and Foreign Patents Pending.

The ROTO-MIX® Forage Express Mixing System

A livestock manager's perspective on preparing hay to feed in a ration

A BETTER WAY!

*“When the hay is in the field we care for it like a newborn calf. We water it, spray it for insects, use the proper equipment to handle it gently so we don't damage the leaf...then when it comes to preparing it to feed, we put it in a tub grinder and beat it to death. There has got to be a better way!”*

An identical ration—baled hay processed and mixed by:

# Your



**ROTO-MIX**  
FORAGE EXPRESS

**Fresh Fluff** This means big nutritional advantages for lower cost of gain or increased milk production. ROTO-MIX consistently produces premium quality feed by lifting the ingredients past the lower auger's wedge point, resulting in a fresher, fluffier ration that insures increased consumption.

**More Leaf** The gentle tumbling action with the ROTO-MIX system mixes fragile ingredients, such as hay leaves, flakes, and high-moisture grain, without causing excessive damage. More leaf in the mix means more protein to your herd.

**Total Mixed Rations** Our thorough mixing action eliminates dead spots and corner pile-up giving you a consistent balance of nutrients from the first pound of feed to the last.

**Fresh Cut** The ROTO-MIX Hay Processor keeps the hay out of the mixing chamber until the knives on the top auger cut...not beat...the hay. The result is hay, with leaves intact, cut to the proper length, resulting in fewer incidents of acidosis.

**More Nutritious** Conventional auger mixers crush, grind and mash all ingredients, which create more fines in the bunk...a waste of your feeding dollars. The ROTO-MIX tumbling action mixes all ingredients, even fragile and flaked, without excessive breakage.

**Fines** With the ROTO-MIX mixing system there's less grinding of flaked, and high moisture grain, pellets or other ingredients so you'll have less fines in the bunk which means less wasted feed... giving you the most for your feed dollars.

**Shrinkage** Our unique ability to process baled hay as you need it results in less wind shrinkage when loading and processing. You'll get the most out of your feed ingredients.

**Supplemental Flexibility** The thorough mix provided by ROTO-MIX eliminates unpleasant tastes associated with certain supplements, allowing you more options when choosing feed supplements.

# Benefits



**T**HE ROTO-MIX professionals know that quality feed means increased consumption,

therefore, higher production levels. With ROTO-MIX Forage Express Mixers you reduce fines, minimize shrinkage, and eliminate dead spots. The gentle tumbling action mixes fragile flaked and high-moisture ingredients without grinding, resulting in a fluffier, more nutritional and palatable ration.

Nothing robs a ration of nutritional value more than fines. Conventional auger mixers use pressure to move the feed through the mixing chamber, thus crushing the feed and creating fines. But the ROTO-MIX patented mixing system uses a rotor to gently lift the feed past the wedging point of the lower side auger, keeping fines to a minimum and reducing nutritional loss.

Even the most nutritious ration is effective only if the cattle eat the complete ration. Improperly mixed feed allows the cattle to "nose out" what they don't want, disrupting the balance of nutrients. But the ROTO-MIX end-to-end...side-to-side mixing system provides the most thorough TMR available, ensuring that your cattle will consume a balanced ration of nutrients in every pound of feed they eat.

## CONVENTIONAL TUB GRINDER AND AUGER MIXER

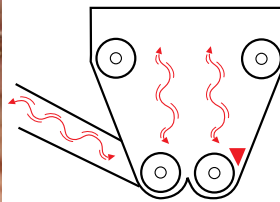

Conventional auger mixers use force and pressure which results in higher power requirements. Excessive bottom auger pressure compresses and crushes feed ration fiber that creates fines.

**ROTO-MIX**  
FORAGE EXPRESS



Bring the freshness of the field to your hay ration.

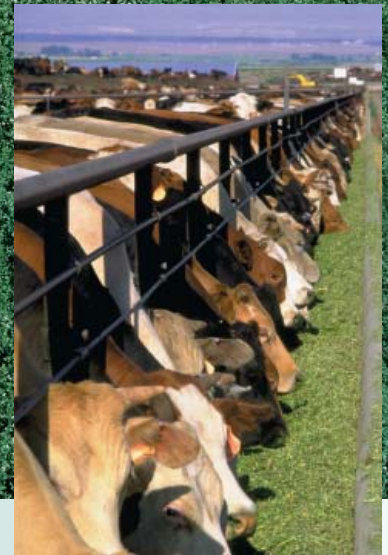

# Trucks



Rotor is equipped with spring tension bars which relieve pressure and eliminate wedging of bulky materials. The UHMW wiper blades are adjustable for fast, effective clean-out.

Note: Inside of units shown above have been painted to show detail only.



Flaired tub side increases tumbling action with ration containing hay or other long stem forages.

- A lower center of gravity puts less shock load on the axle and springs when cornering or driving over rough terrain.
- Patented double flighted upper auger working in conjunction with the ROTO-MIX hay processing system increases hay inclusion levels.
- Short wheel base allows tight turns and easy maneuverability.
- Stainless steel tub and end liners are available in 10 or 12 gauge material for extended mixer shell life.



## Augers

Only two augers with one-half to two-thirds less flighting than most conventional auger mixers. Extra-heavy, small diameter wall auger tubes give maximum life with less maintenance. Hay knives are hard surfaced to provide a self-sharpening effect, thereby cutting the hay to the proper length while giving the knives an extended life.



## Floating Lower Auger

Floating lower auger available with hay processor option relieves pressure when wet or grassy chunks of hay are inadvertently loaded into the mixer.



## Flanged, Double Flighted Top Auger

Flanged rotor and augers allow for easy removal. Patented double flighted top auger keeps large chunks of hay out of the mixing chamber until processed.



## Rotor

The patented rotor lifts feed up to the side augers that move the feed from end-to-end for thorough mixing. The lifting action of the rotor eliminates wedging of the hay or long cut feeds under the lower auger. Patented tumbling design allows easier pulling mixer action, reducing the load on the PTO, drive line and transmission.



## Grease Bank

The single point grease bank allows easy access to main lubrication points from the ground.



## Rear Doors

Easy access rear doors with single point latches.



## Clean-Out

Rotor design keeps the lower auger at full capacity for quicker clean-out...no waiting on the last few hundred pounds.



## Door, Spout, Magnets

To control feed flow, the variable discharge door is hydraulically operated and can be opened or closed with the mixer running. Wide gravity discharge spout has no moving parts. Optional magnets in spout trap foreign metal before it reaches the feed bunk.



## Folding Conveyor

Hydraulically driven conveyor available in 24", 36" and 48" lengths for extra reach and height.



## Drive

Complete extra-heavy-duty drive assembly runs in an enclosed oil bath.



## Hay Processor

The Hay Processor keeps large chunks of hay out of the mixing chamber until processed by the knives on the top auger.



## Trailer Frame

Heavy duty tubular trailer frame ensures long life and maximum scale accuracy.



## Tongue and Hitch Clevis

Adjustable hitch clevis allows an operator to level mixer with most tractors to maximize mixer efficiency. Single pole tongue allows the tightest turning radius possible.

# Trailers

Trailer models are mounted on heavy-duty tubular steel trailer frames, complete with built-in scale mountings. Heavy-duty eight- or ten-bolt hubs and spindles with a selection of tires for eight- and ten-hole wheels. The single pole trailer tongue is constructed of heavy-wall tubing for a shorter turning radius. A sturdy rear bumper and an adjustable, replaceable trailer hitch clevis are also standard equipment.



ROTO-MIX mixers feature industry-leading electronic scale systems for accurate and reliable ration batching. Choose from compression-type load sensors that feature a  $\frac{1}{10}$  of 1% accuracy or bar-type sensors that have  $\frac{1}{2}$  of 1% accuracy. We offer indicators with capabilities ranging from basic weigh-up, weigh-down to radio frequency, computer compatible systems, and everything in between.





Electric motor drive.

# Stationary

Forage Express stationary units are equipped with the same quality mixing features as the truck and trailer mounted units. Forage Express Mixers are available in 5 sizes. Each are energy-efficient and suitable for overhead or ground-level installation. Their higher side discharge location allows easier loading of your conveyor or leg while maintaining a minimum mixer height.



Check all the ROTO-MIX advantages...  
the bottom line is what counts.



DIMENSIONS	184-10B	274-12B	354-12B	414-14B	524-15B
Weight—Stationary-Less Motor	5,540 lb. (2,512.9 Kg)	7,150 lb. (3,243.2 Kg)	8,540 lb. (3,873.7 Kg)	9,900 lb. (4,490.5 Kg)	12,560 lb. (5,697.1 Kg)
Weight—Truck Unit-Installed	N/A	7,720 lb. (3,501.7 Kg)	8,940 lb. (4,055.1 Kg)	10,340 lb. (4,690.1 Kg)	13,390 lb. (6,073.6 Kg)
Weight—Trailer with Tires	6,350 lb. (2,880.3 Kg)	8,060 lb. (3,655.9 Kg)	9,640 lb. (4,372.6 Kg)	11,040 lb. (5,007.6 Kg)	14,650 lb. (6,645.1 Kg)
Weight—Hay Processor	500 lb. (226.8 Kg)	680 lb. (308.4 Kg)	680 lb. (308.4 Kg)	720 lb. (326.6 Kg)	750 lb. (340.2 Kg)
Rotor Diameter	48 in. (122 cm)	54 in. (137 cm)	60 in. (152 cm)	60 in. (152 cm)	68 in. (173 cm)
Inside Length	120 in. (305 cm)	144 in. (366 cm)	144 in. (366 cm)	168 in. (427 cm)	180 in. (457 cm)
Inside Width	71 in. (180 cm)	80 ½ in. (204 cm)	92 in. (234 cm)	92 in. (234 cm)	99 in. (251 cm)
Overall Length—Mixer Only	137 ½ in. (349 cm)	163 ½ in. (415 cm)	163 ½ in. (415 cm)	187 ½ in. (476 cm)	204 in. (518 cm)
Overall Width—Mixer Only	78 in. (198 cm)	87 ½ in. (222 cm)	100 ½ in. (255 cm)	100 ½ in. (255 cm)	106 in. (269 cm)
Overall Width—Spout Up	80 in. (203 cm)	90 in. (229 cm)	102 in. (259 cm)	102 in. (259 cm)	108 in. (274 cm)
Overall Length Including Trailer	192 in. (488 cm)	216 in. (549 cm)	221 in. (561 cm)	242 in. (615 cm)	264 in. (671 cm)
Overall Length-Stationary Drive	149 in. (378 cm)	175 in. (445 cm)	175 in. (445 cm)	198 in. (503 cm)	216 in. (549 cm)
Height of Mixer-Base to Top	53 in. (135 cm)	59 in. (150 cm)	65 in. (165 cm)	65 in. (165 cm)	72 in. (183 cm)
Height of Mixer-Oil Bath Drive	58 ½ in. (149 cm)	65 ½ in. (166 cm)	71 ½ in. (182 cm)	71 ½ in. (182 cm)	80 ½ in. (204 cm)
Height on Trailer-Std. Tires	82 in. (208 cm)	88 in. (224 cm)	96 in. (244 cm)	96 in. (244 cm)	107 in. (272 cm)
Height on 36" Truck Frame	N/A	101 in. (257 cm)	106 in. (269 cm)	106 in. (269 cm)	113 in. (287 cm)
Height on Stationary Scale Frame	63¾ in. (162 cm)	69¾ in. (177 cm)	78 in. (198 cm)	78 in. (198 cm)	83 in. (211 cm)
Spout Width—Truck & Trailer	35 in. (89 cm)	35 in. (89 cm)	35 in. (89 cm) (A)	35 in. (89 cm) (A)	47 in. (119 cm)
Discharge Frame Width-Stationary (B)	22¾ in. (57 cm)	22¾ in. (57 cm)	34¾ in. (87 cm) (A)	34¾ in. (87 cm) (A)	34¾ in. (87 cm) (A)
Truck Cab to Axle	N/A	108 in. (274 cm)	108 in. (274 cm)	114-120 in.(290-305 cm)	120-130 in. (305-330 cm)
Cubic Ft. Capacity, Struct Level	210 (5.94 m³)	315 (8.91 m³)	400 (11.32 m³)	460 (13.02 m³)	570 (16.13 m³)
Cubic Ft. Mixing Capacity	180 (5.09 m³)	270 (7.64 m³)	350 (9.91 m³)	410 (11.60 m³)	520 (14.72 m³)
Bushel Mixing Capacity	144 (5,074 liter)	216 (7,612 liter)	280 (9,867 liter)	328 (11,558 liter)	416 (14,659 liter)
Maximum Rating with Heavy Ration	5,400 lb. (2,449.4 kg)	8,100 lb. (3,674.2 kg)	10,500 lb. (4,762.8 kg)	11,500 lb. (5,216.4 kg)	14,500 lb. (6,577.2 kg)

#### SPECIFICATIONS

Tub Bottom (A)	¾ in. (0.9525 cm)	¾ in. (0.9525 cm)	¾ in. (0.9525 cm)	¾ in. (0.9525 cm)	¾ in. (0.9525 cm)
Auger Bottom (A)	¾ in. (0.9525 cm)	¾ in. (0.9525 cm)	¾ in. (0.9525 cm)	¾ in. (0.9525 cm)	¾ in. (0.9525 cm)
Ends	7 ga. (0.4547 cm)	7 ga. (0.4547 cm)	7 ga. (0.4547 cm)	7 ga. (0.4547 cm)	¼ in. (0.6350 cm)
Upper Sides	10 ga. (0.3404 cm)	10ga. (0.3404 cm)	10 ga. (0.3404 cm)	10 ga. (0.3404 cm)	7 ga. (0.4547 cm)
Top Auger Flight (A)	¾" x 16" OD (.95 x 40.6 OD cm)	¾" x 16" OD (.95 x 40.6 OD cm)	¾" x 20" OD (.95 x 50.8 OD cm)	¾" x 20" OD (.95 x 50.8 OD cm)	¾" x 20" OD (.95 x 50.8 OD cm)
Lower Auger Flight (A)	¾" x 16" OD (.95 x 40.6 OD cm)	¾" x 16" OD (.95 x 40.6 OD cm)	½" x 20" OD (1.27 x 50.8 OD cm)	½" x 20" OD (1.27 x 50.8 OD cm)	½" x 20" OD (1.27 x 50.8 OD cm)
Auger Drive—Roller Chain	#50,60,80	#60,80,100	#60,80,100	#60, 80, 100HT	#80, 100, 120
Rotor Drive—Roller Chain	#80	#100	#100	#100HT	#120
Top Auger Drive Shaft	2 in. (5.08 cm)	2 ½ in. (6.35 cm)	2 ½ in. (6.35 cm)	2 ½ in. (6.35 cm)	3 in. (7.62 cm)
Lower Auger Drive Shaft	2 ½ in. (6.35 cm)	3 in. (7.62 cm)	3 in. (7.62 cm)	3 in. (7.62 cm)	3 ½ in. (8.89 cm)
Rotor Drive Shaft	3 in. (7.62 cm)	3 ½ in. (8.89 cm)	3 ½ in. (8.89 cm)	3 ½ in. (8.89 CM)	4 in. (10.16 cm)
Horsepower—Electric (Hay Processor)	15 (11.19 kilowatts)	20 (14.92 kilowatts)	25 (18.65 kilowatts)	30 (22.38 kilowatts)	30 (22.38 kilowatts)
Horsepower—Electric (Standard)	10 (7.46 kilowatts)	15 (11.19 kilowatts)	20 (14.92 kilowatts)	25 (18.65 kilowatts)	30 (22.38 kilowatts)
Horsepower—Electric (Optional)	10 (7.46 kilowatts)	10 (7.46 kilowatts)	15 (11.19 kilowatts)	20 (14.92 kilowatts)	25 (18.65 kilowatts)

(A) Other options available

(B) Special door sizes and locations available for all stationary mixers  
Dimensions and specifications subject to change without notice.

Weights listed with most common option packages excluding hay processors and folding conveyors.

## Plant Tours Available



ROTO-MIX, LLC • 2205 E. Wyatt Earp • Dodge City, Kansas 67801 U.S.A. • Phone (620) 225-1142 • www.rotomix.com

Distributed by: